



TRANSCRAFT[®]
DTL-3000[™]

DTL-3000 Standard Specifications

Front Plate	Fabricated Hi Tensile Steel, square corners, no stake pockets.
Rear Plate	Hi Tensile Steel, 13" deep section with internal stake pockets and recessed lites with back fully enclosed. 11 1/4" deep extra heavy duty rubber dock bumpers along with a 4" x 5" tubing bumper and heavy duty bracing provide maximum protection for the rear of the trailer.
5th Wheel Plate	SAE King pin, 30" location, 1/4" skid plate tapers up front for easy pickup. 24" or 36" location optional.
Main Beam (Lightening holes in web)	Built for maximum payload with a beam capacity of 85,000# in 10' or 80,000# in 4'. Assembled with heat treated 130,000# yield strength flanges and high tensile steel webs. GVWR 80,000# 1/2" x 5" 130K Flanges 3/8" G. N. & 1/4" Web
Upper Frame	4" Jr I Sills, 12" O/C.
Lower Frame	Pipe Braces running from bottom of sills to main beams with matching inner cross pipe.
Side Rail	10 gauge fabricated Side Rail, 1 5/8" x 3 1/2" x 3 1/2" x 1/4" stake pockets, 3/8" x 2 1/2" rubrail with recess for reflective tape, double pipe spools between pockets.
Landing Gear	Premium EZSHIFT gear on Binkley 51000, 140,000# static load rated legs with 10" x 10" square shock-mounted sand shoes.
Suspension	IntraaxAA-230L Airide with "Quick-Align" feature.
Axles	Integral axle with tapered spindle, type 3030 MGM spring brakes, and Haldex automatic slack adjusters.

Wheels	8.25-22.5 hub piloted steel disc, outboard mounted cast hubs and drums.
Brakes	Premium Extended Service Brake lining, 16.5 x 7" with anti-lock braking sensors on every wheel. Meritor Wabco 4S2M ABS is used for maximum brake life and virtual elimination of flat spotted tires.
Electric	Male pin connectors to all lights with double seals. Locked in place with a positive retention pin to eliminate the biggest reason for wiring problems - loose connections. All required splices are sonic welded. All wires are double insulated in a sealed loom with molded double seals. This system was designed for Transcraft by USA Harness. Exclusive Grote male pin connection <u>LED lights are standard</u> for a total lifetime, trouble free, electrical system with a 5 year warranty on materials and labor. This system includes 25 lights, 2 on front, 5 on each side, 2 large 4" mid wide turn lights, 6 combination 4" rear lights, 3 round identification lights, ABS lamp, and an incandescent license light. There is a simple plug-in provision for accessory power.
Floor	1 1/8" Apitong with Shiplapped Edges.
Paint	Steel components are cleaned, phosphatized, and primed with a 2-part universal primer, then painted with a 2-part black urethane.
Reflective Tape	The highest quality 3M reflective tape is installed in the recess of the rubrail for protection, throughout the trailer except on the rear cross tube of bumper.
Tires	255/70R22.5 General ST250LP

10' Beam Capacity		4' Beam Capacity	
49" Axle Spacing	121" Axle Spacing	49" Axle Spacing	121" Axle Spacing
80,000#	85,000#	75,000#	80,000#

REV	REVISION CHANGE DESCRIPTION	BY	DATE	ECN
-----	-----------------------------	----	------	-----

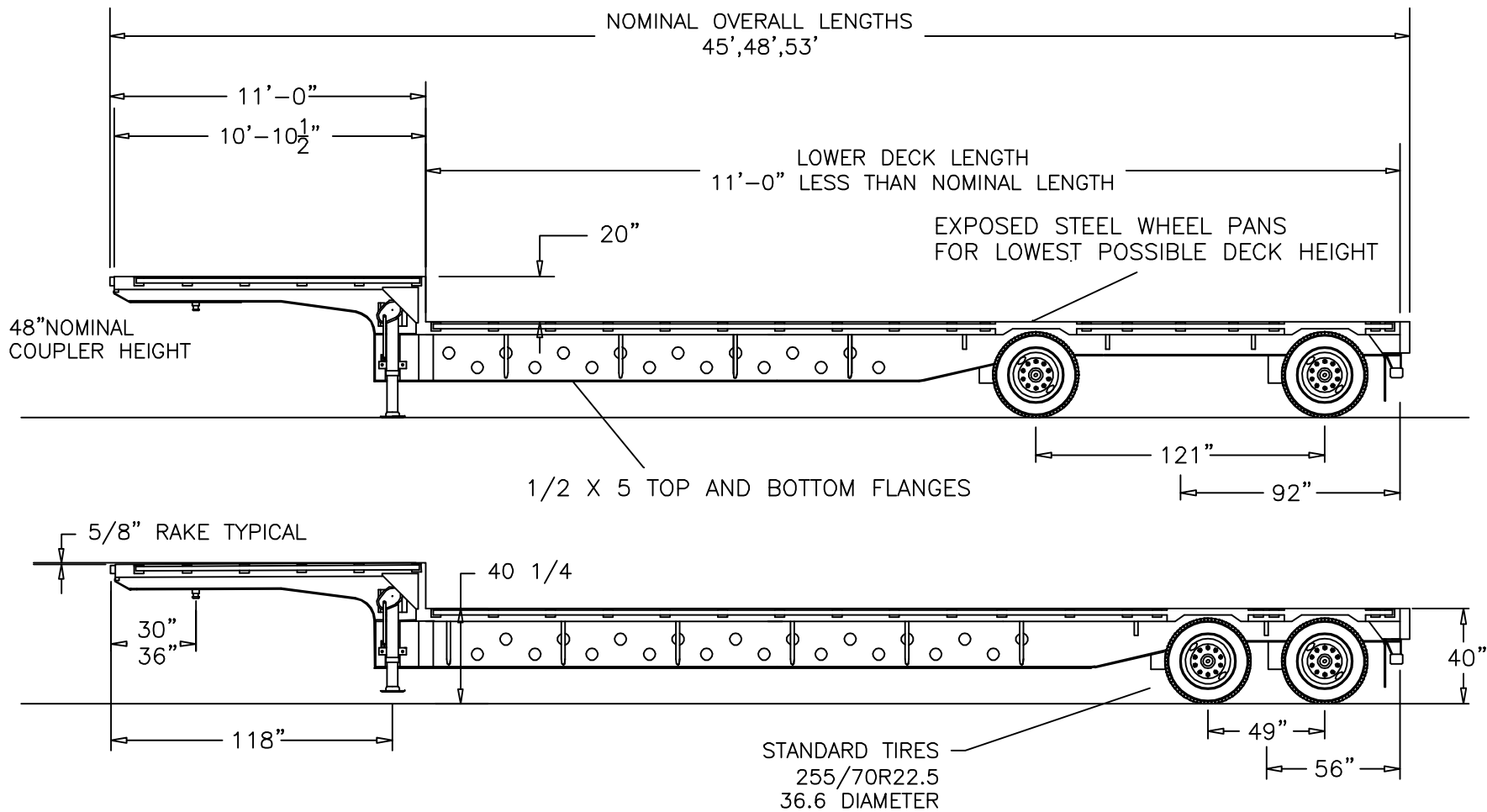

THE FOLLOWING TOLERANCES
APPLY TO ALL DIMENSIONS
UNLESS OTHERWISE SPECIFIED
FRACTIONAL: +/- 1/2"
DECIMAL: +/- .005"

Transcraft

DR. BY: SMG	NAME: DTL-3000	REV D
WEIGHT:	DATE: 7/18/03	P/N: S148372
		SHEET 1 OF 1